

Description

The Autani External Antenna Extension Kit expands the range of the Autani Manager/CORE wireless network, allowing devices to communicate with each other over larger distances. The Extension Kit is perfect for outdoor applications like parking lots and parking garages. It is also extremely helpful for use in buildings constructed from materials like concrete that typically inhibit wireless signal performance.

A dedicated range extension device, the External Antenna Extension Kit adds a high-powered radio to the wireless mesh for the purpose of extending the range of the network. Because the Extension Kit performs no other functions, it can effectively route and extend the network better than a node that is used for multiple purposes.

Applications

External Antenna Extension Kits are suitable for renovation, upgrade, and new construction projects.

- Parking Lots & Garages
- Classrooms & Gymnasiums
- Warehouse Spaces & Manufacturing Areas
- Transportation Terminals
- Retail & Grocery Stores



Features

- Cost effectively expands the range of a wireless network
- Excellent for outdoor applications and buildings made of materials like concrete that inhibit wireless signal performance
- Simple to install using Autani's auto-commissioning software features
- Easy to add in nearly any location needed
- Provides reliable communication between devices
- *EnergyCenter* products operate independently or as an integrated solution with other members of the *EnergyCenter* family
- **Designed & Made in the USA**

Specifications

ELECTRICAL

- Input Voltage: 12-30V AC/DC
- Input Current: 100mA max.

RADIO NETWORK (autaniNet)

- IEEE 802.15.4-2003 2.4GHz ISM
- Range: Up to 2000' LOS transmit/ receive

REGULATORY APPROVALS

- FCC ID: V8NZRB1000152
- IC: 7737A-ZRB1000152

ENVIRONMENTAL

Test condition of all ratings 25°C

- Operating Temperature: 0° to 60°C
- Storage Temperature: -25° to 80°C
- Rated for indoor use only

PHYSICAL

- Dimensions (HxWxD): 3.35 x 1.07 x .71in
- Dimensions of gang box (HxWxD): 4.97, 3.87, 2.3in
- Color: White
- Weight/ Shipping Weight: <10 oz/<1lb

Dimensions

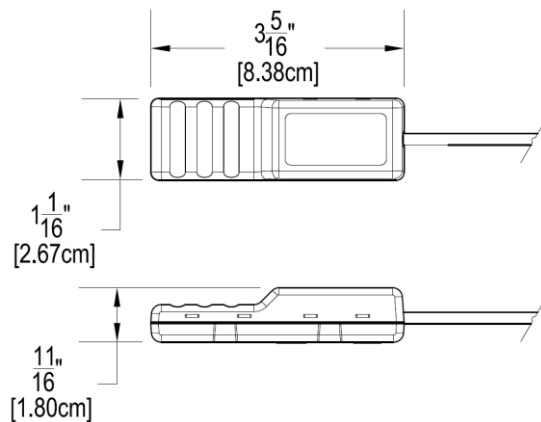

Ordering Information

SKU / ID	Description
A07-01-0403-09 EXTANT25	Kit, External Antenna, Manager/CORE, 25'
A07-01-0403-10 EXTANT50	Kit, External Antenna, Manager/CORE, 50'
A07-01-0403-11 EXTANT25-OUT	Kit, External Antenna, Manager/CORE, 25', Outdoor
A07-01-0403-12 EXTANT50-OUT	Kit, External Antenna, Manager/CORE, 50', Outdoor

Gang Box Assembly

